



**THE MOST UNIVERSAL**

**UNCOUPLING AND**

**SOUND DEADENING BOARD**

**New OkaQuiet**

 **Kiesel**

Hardwood and  
engineered wood flooring



Resilient  
flooring



Tiles

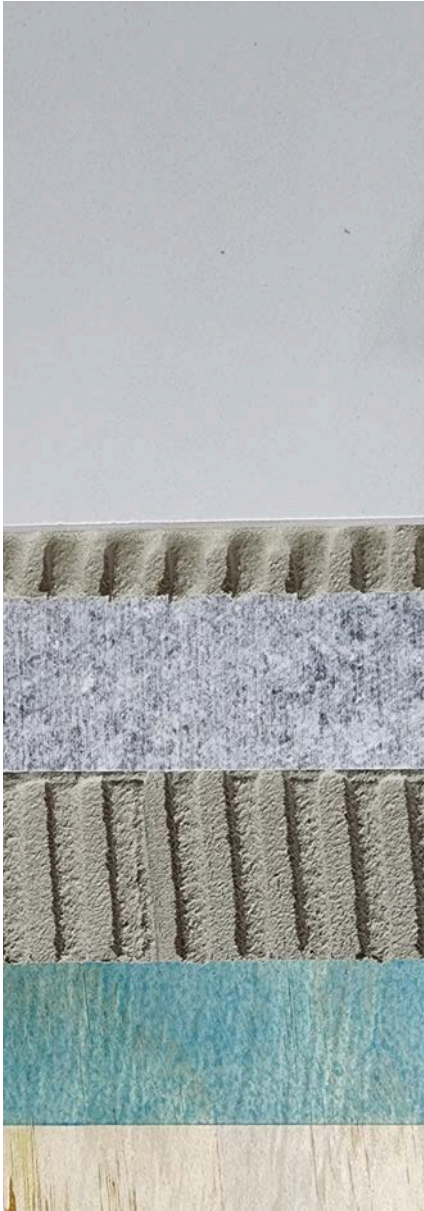

# **NEW** Universal OkaQuiet – Uncoupling and Sound Deadening Board

## **INSTALLATION MANUAL AND TECHNICAL DATA SHEET**

Excellent uncoupling and sound deadening properties	Under heated cables, heating mats
Weighted, tension-free, thus creating an even and smooth substrate for tiling	For large format tiles**
For the interior, floor and wall applications and wet areas, e.g., in apartments, houses, or hotel rooms outside of the shower and tub surround areas***	Glue down engineered wood and resilient flooring*
Only 5/32", 4 mm thin	Will not deteriorate
No echoing sound, full mortar transfer under and over, full tile support	Flexible and sturdy
Increased walking and living comfort	Easy to install
Easy to mark on and see chalk lines for your convenience	Can be cut, scored, sawn
Approx. 30 % in mortar savings (no pre-floating of "waffles") compared to other existing uncoupling membranes	Contributes to LEED – 90 % of post-consumer recycled content
Insulating properties	VOC-free and environmentally safe
Over existing radiant heated floors	Reduces step sound by 10 dB according to DIN and EN ISO 10140
	ASTM E90-09 (2016), ASTM E413-16, ASTM E492-09 (2016) e1, ASTM E2179-21, ASTM E989-21, ASTM E2235-04 (2020), ASTM E3222-20
	ASTM C627-93: Light commercial, residential and extra heavy commercial****

\* Please contact Kiesel Technical Department  
 \*\* Not suitable for floor installations for Gauged Porcelain Tile Panels/Slabs (GPTP). Suitable for wall installations of GPTP  
 \*\*\* Wet areas with appropriate Kiesel waterproofing membranes only  
 \*\*\*\* Light commercial over standard, industry recognized OSB, plywood substrates, Extra Heavy over concrete substrate only.



GEV EMICODE  
 Kiesel Quality and Innovation since 1959

# Kiesel OkaQuiet Uncoupling Board

## FLOORS INTERIOR CERAMIC AND PORCELAIN TILE

### 16" (406 mm) o.c. joist spacing, single layer OSB or plywood subfloor

#### Areas of Application

Over any even and structurally sound OSB or plywood subfloor with 16" (406 mm) o.c. joist spacing – exposure 1, plugged-face plywood or OSB with 1/8" gap between sheets is recommended

#### Substate Specific Requirement

- Maximum spacing of joists, I-joists, or floor trusses is 16" (406 mm) o.c.
- Minimum subfloor thickness – 19/32", 5/8" nom. (16 mm) tongue-and-groove with 1/8" (3 mm) gap between sheets
- Interior dry or wet areas (with designated Kiesel waterproofing membranes)

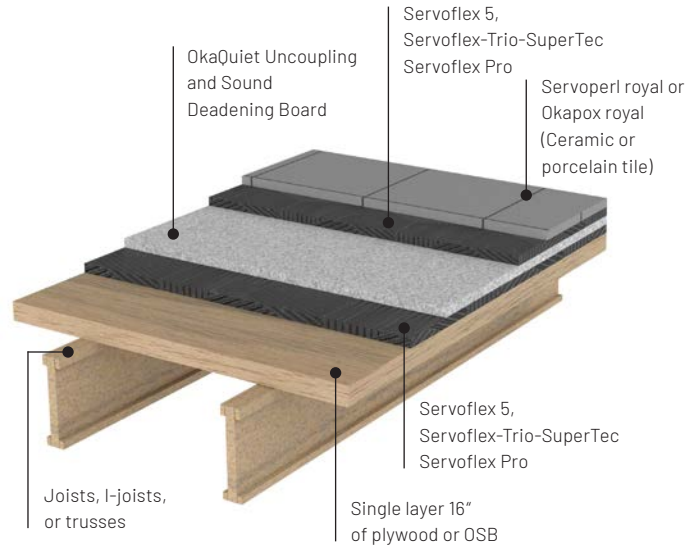

### 19.2" (488 mm) o.c. joist spacing, single layer OSB or plywood subfloor

#### Areas of Application

Over any even and structurally sound OSB or plywood subfloor with 19.2" (488 mm) o.c. joist spacing – exposure 1, plugged-face plywood or OSB with 1/8" gap between sheets is recommended

#### Substate Specific Requirement

- Maximum spacing of joists, I-joists, or floor trusses is 19.2" (488 mm) o.c.
- Minimum subfloor thickness – 23/32", 3/4" nom. (19 mm) tongue-and-groove with 1/8" (3 mm) gap between sheets

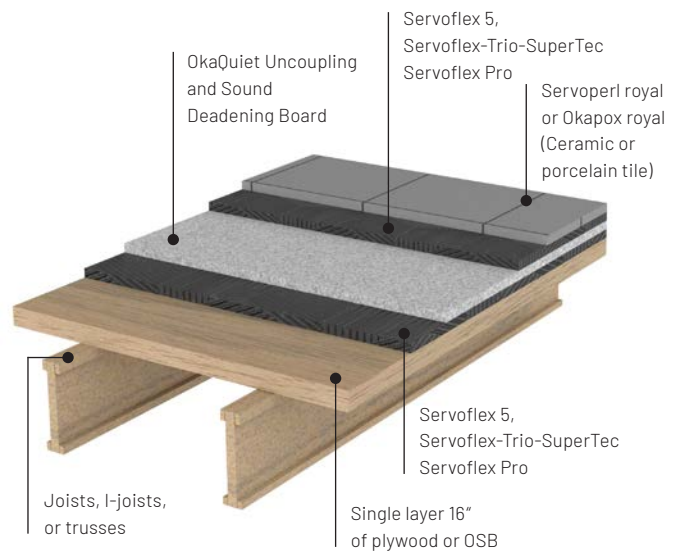

### 24" (610 mm) o.c. joist spacing, double layer OSB or plywood subfloor

Contact Kiesel technical department for recommendations and specification.

# Kiesel OkaQuiet Uncoupling Board

## NATURAL STONE TILE

### Double layer of OSB or plywood subfloor

#### Areas of Application

Over any even and structurally sound double-layer OSB or plywood subfloor – exposure 1, plugged-face plywood or OSB with a 1/8" gap between sheets is recommended

#### Limitations

- Requires double layer wood floor regardless of joist spacing
- Minimum 2" x 2" (50 mm x 50 mm) tile

#### Substate Specific Requirements

Maximum spacing of joists, I-joists, or floor trusses is 16" (406 mm) o.c. double layer wood floor consisting of:

- Minimum subfloor thickness – 1 1/4" (31 mm) tongue-and-groove

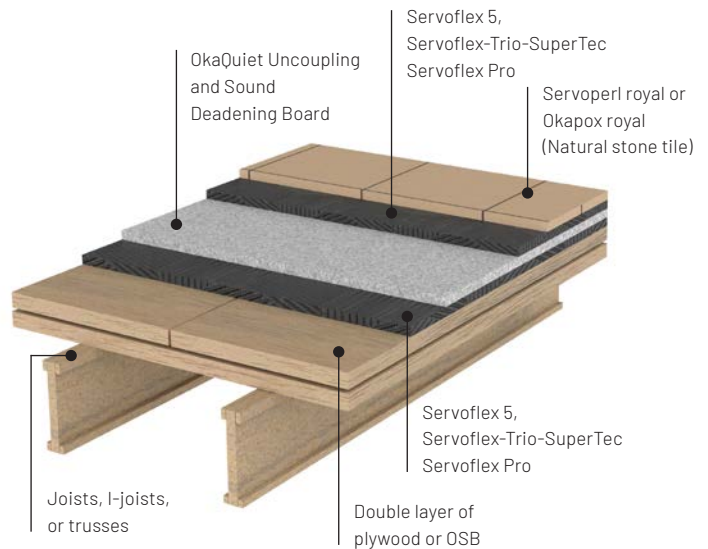

#### Note:

Natural stone coverings can be installed over the OkaQuiet Uncoupling Board after the complete hardening of the installation mortar used to bond the OkaQuiet Board. Ceramic coverings made of stoneware or porcelain tiles with a thickness of more than 8 mm are suitable.

For natural stone coverings, only correspondingly dense types (e.g., granite or gneiss) with a minimum thickness of over 15 mm or breaking strength of 1500 N.

Special considerations apply when sizing floor joists to support ceramic or stone tiles (marble, granite, limestone, slate, etc.). Tile industry associations recommend that floor joists be spaced 16 inches (40.6 cm) on center or less. The Tile Council of America recommends limiting deflection to L/360 (L = span length in inches) under total load for ceramic tile. The Marble Institute of America recommends that total load deflection be limited to L/720 for spans up to 14'-0" and a maximum deflection of 7/32" for spans greater than 14'-0".

Stone tiles may be installed with thin-set methods (a 14-foot (4.26 meters) maximum span is recommended by the Marble Institute of America), and ceramic tiles may be set on a full mortar bed. Adjust the dead load as required to reflect the actual system components and apply the appropriate deflection limit for the type of tiles to be used.

# Kiesel OkaQuiet Uncoupling Board Floors

## FLOORS, INTERIOR – STRUCTURAL PLANK SUBFLOOR

### Areas of application

Over structural plank subfloors, interior dry or wet areas

### Requirements

Maximum spacing of joists is 24" (610 mm) o.c. double layer wood floor consisting of:

- Minimum structural plank subfloor thickness –  $\frac{3}{4}$ " (19 mm)
- Minimum underlayment thickness –  $\frac{15}{32}$ ",  $\frac{1}{2}$ " nom. (13 mm)

### Substrate Specific Preparation

Verify that subfloor planks are correctly fastened to framing joist members underlayment – minimum  $\frac{15}{32}$ ",  $\frac{1}{2}$ " nom. (13 mm)-thick Exposure 1, plugged-face plywood or OSB with  $\frac{1}{8}$ " (3 mm) gap between sheets. Any levelling of the assembly must be done before the installation of the OkaQuiet Uncoupling Board

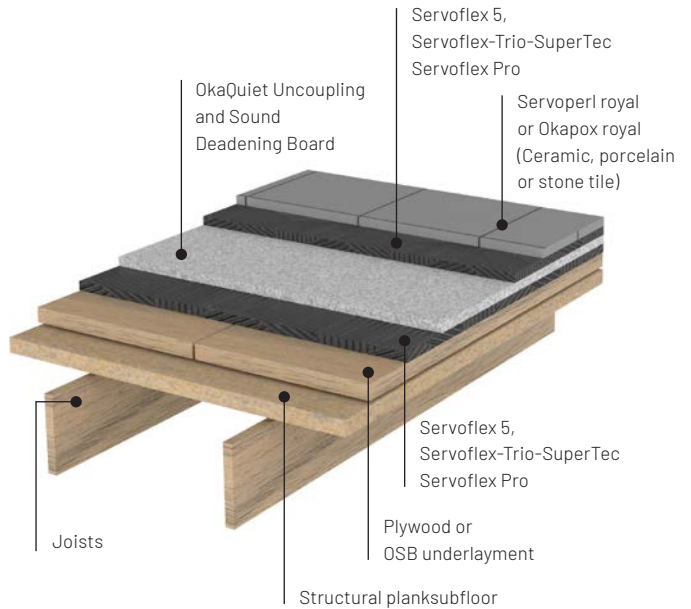

# Kiesel OkaQuiet Uncoupling Board

## CONCRETE SUBSTRATE, RADIANT HEATED FLOOR

### Areas of Application

- Structural concrete slab
- Over any structurally sound and even concrete subfloor
- Young concrete (concrete cured less than 28 days) on or below grade concrete subject to moisture migration
- Post-tensioned or pre-stressed concrete cracked concrete

### Limitations

Any cracks in the concrete subfloor must exhibit in-plane movement only; thin-set tile assemblies, including those incorporating OkaQuiet Uncoupling Board, cannot accommodate differential vertical displacement

### Substate Specific Requirements

Slab to be structurally sound and free of waxy or oily films and curing agents (when present, mechanical scarifying is necessary). The OkaQuiet Uncoupling Board installation can begin after successfully completing the radiant heating protocol for concrete and gypsum substrates. Refer to the heating cycling document located on page 19. Concrete slab to be free of standing water and excessive relative humidity content.

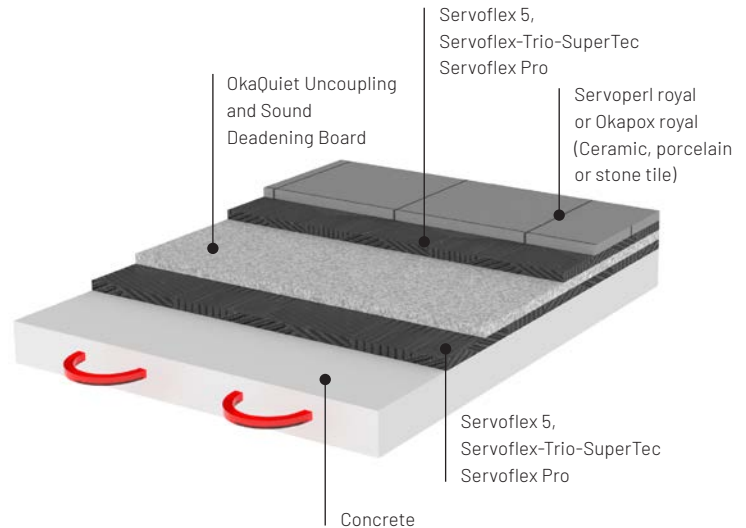

# Kiesel OkaQuiet Uncoupling Board Floors

## HEATING MATS AND WIRES OVER PLYWOOD, OSB, CONCRETE AND GYPSUM-BASED SUBSTRATES

### Areas of Application

Over gypsum underlayment placed over structurally sound wood or concrete subfloors interior dry or wet areas

### Requirements

For wood substrates, subfloor/underlayment Substrate Preparation for gypsum screeds – follow manufacturer’s directions

### Heating mats installation procedure:

Install mats per manufacture recommendations. To install mats and tiles use Servoflex 5 royal, Servoflex-Trio-SuperTec, Servoflex Pro, Servoflex-Trio-schnell SuperTec. Kiesel doesn’t recommend installing tiles immediately after fixing the electrical mat. Please look at the table above concerning recommended waiting time

### Heating wire installation procedure:

Install heating wire per manufacture specificati- ons on the surface of OkaQuiet. To embed heating wire, use Servoplan Ki 1 with Kiesel fibres or Servoflex 5 royal, Servoflex-Trio-SuperTec, Seroflex Pro, Servoflex-Trio-schnell SuperTec (Quick set) in thickness not exceeding 5 mm (3/16”). Proceed with tile installation when mortars and self-levellers used to imbed heated wire are completely dry.

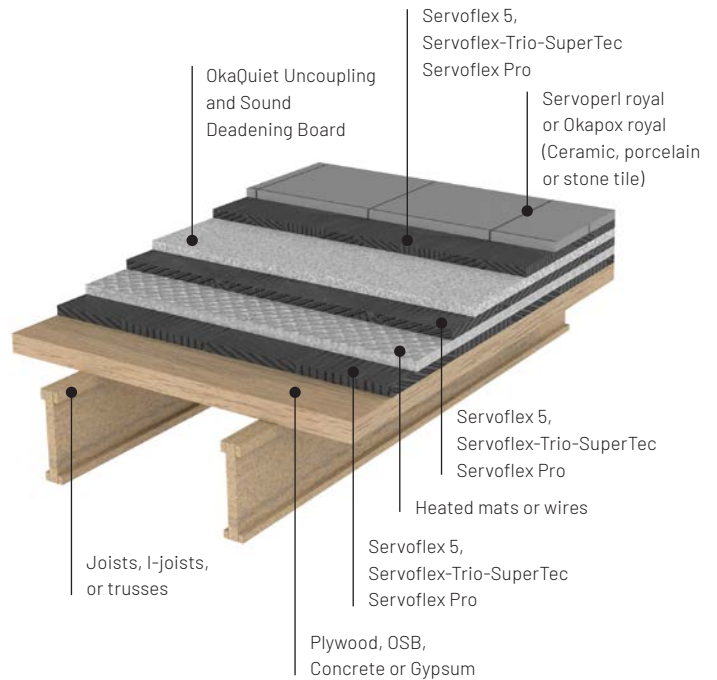

### Kiesel thinset drying time under OkaQuiet

<b>Servoflex 5 royal</b>	min. 6 hours *	before tile/heated coils, heating mats installation
<b>Servoflex-Trio-schnell SuperTec</b>	min. 8 hours *	before tile/heated coils, heating mats installation
<b>Servoflex-Trio-SuperTec</b>	min. 12 hours *	before tile/heated coils, heating mats installation
<b>Servoflex Pro</b>	min. 12 hours *	before tile/heated coils, heating mats installation

### Kiesel thinset drying time over OkaQuiet

<b>Servoflex 5 royal</b>	min. 6 hours *	before grout installation**
<b>Servoflex-Trio-schnell SuperTec</b>	min. 8 hours *	before grout installation**
<b>Servoflex-Trio-SuperTec</b>	min. 12 hours *	before grout installation**
<b>Servoflex Pro</b>	min. 12 hours *	before grout installation**

\*\*For stone installations, please contact Kiesel technical department

When installing heating mats, please contact Kiesel technical department.

The heated surface can be fully operational after approximately 4-7 days, subsequently to grouting\*.

Always set the temperature on your controls gradually.

Follow local/ national specifications regarding tile installation and floor preparation located in TTMAC and TCNA installation manuals.

\*At 68° F (+20° C) and 65 % relative humidity. Higher temperatures and low humidity decrease, lower temperatures and high humidity increase this value, respectively.

# General requirements and guidelines for all substrates

## Substrate preparation

The substrate must be sound, clean and stable. Level uneven substrates with Servoplan Ki 1 (add Kiesel fibres over wooden substrates, OSB, plywood) or Servocret RS underlayment before installing the insulating board. Use Servoplan Ki 1 and Kiesel fibres if the substrates are not dimensional stable (OSB Board, plywood).

Concrete, cementitious substrates prime with Okatmos® UG 30 or Okatmos® DSG (do not use over radiant heated concrete or gypsum based substrates) following the latest Kiesel TDS.

Verify that subfloor panels are sound and correctly fastened to framing joist members any levelling of the subfloor must be done before installing OkaQuiet Uncoupling Board. However, where levelling is required over OkaQuiet, it cannot exceed  $\frac{3}{8}$ ". Use Servoplan Ki 1 with Kiesel fibres over OkaQuiet.

Wood composite substrates (OSB, plywood) prime with Okatmos® UG 30 or Okatmos® DSG and/or Okapox GF per Kiesel TDS. Wet areas, for example, bathrooms, washrooms with nominal moisture content, and waterproofing membranes, may be required. Use Okamul DF, Servoflex DMS 1K Plus SuperTec.

Double layered plywood substrates must be dry, APA-rated, Type 1, COFI Group exterior-grade plywood, certified CANPLY (SELECT) or (SEL-TF) CSA 121, minimum 32 mm (1  $\frac{1}{4}$ ") total thickness in residential and light commercial and dry conditions only. Refer to ANSI A 108 AN-2 „General Requirements for Sub surfaces“ and the Tile Council of North America’s „Handbook for Ceramic Tile Installation“ for detailed information on

surface preparation and guidelines for substrate construction. Follow deflection allowance in accordance with ASTM C627 Standard test method. In some cases, the maximum deflection must not exceed L/720.

## Installation

Dry lay OkaQuiet Uncoupling Boards loosely staggering, offsetting it by 50% in a brick pattern connecting joints so that they fit tightly, ensuring that the panels do not peak when being butted together. Keep the OkaQuiet 5mm /  $\frac{3}{16}$ " away from the wall or columns. Use of the Kiesel edge strip is recommended for this purpose, especially when installing tiles that require sound-deadening solutions. Cut or saw the board with a circular saw, jig saw or heavy-duty utility knife. Remove the farthest section from your exit and install the OkaQuiet section by section leading to the exit. Use either Servoflex 5 royal, Servoflex-Trio-schnell SuperTec (Quick set), Servoflex-Trio-SuperTec or Servoflex Pro by using a 6 mm square notched trowel ( $\frac{1}{4}$ " x  $\frac{1}{4}$ " x  $\frac{1}{4}$ ") providing full mortar transfer. Lift boards occasionally check for proper coverage. Insert boards within approx. 15-20 minutes and press firmly. Use a flat trowel, grout float or weighted rollers (50 to 75 lbs. of weight) to press the OkaQuiet Board into the mortar bed. Avoid entrapping air underneath OkaQuiet. Remove any mortar excess from the boards surface. Begin with tile installation after 12 hours of dry time\*.

Leave (5–7 mm or  $\frac{3}{16}$ "– $\frac{9}{32}$ ") gaps around the outside border line of OkaQuiet, making sure not to bond the OkaQuiet Board to perimeter walls. Use Kiesel wall perimeter seal gasket for this purpose and cut the strip excess only after grouting is completed.

When using OkaQuiet as sound deadening, apply generic masking tape ( $\frac{3}{4}$ ") to all connecting seams to prevent mortar to mortar bond from preventing sound transmission into the coverings.

Install coverings with a thin bed mortar such as Servoflex 5 royal, Servoflex-Trio-schnell SuperTec (Quick set), Servoflex-Trio-SuperTec, Servoflex Pro. Full mortar transfer is required.

Proceed with tile installation providing proper mortar transfer underneath tiles. Grouting can begin approx. 12 hours after tile installation (\*check drying table). Use Servoperl royal or Okapox royal as grout.

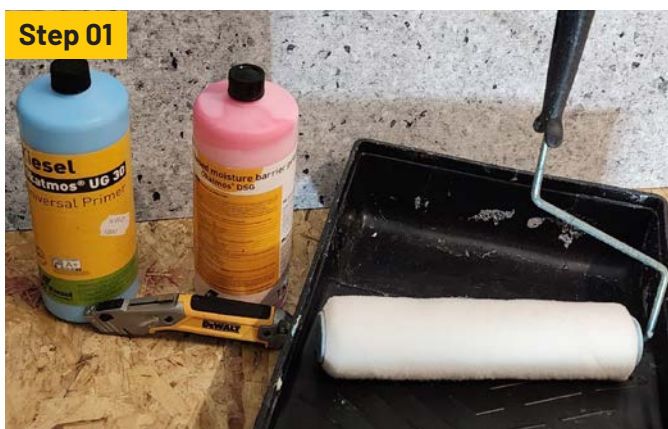

Tools and products required to install OkaQuiet: Okatmos UG 30 or Okatmos DSG, paint roller and heavy duty utility knife.



Spread Okatmos DSG over concrete or wooden substrates...



or Okatmos UG 30 and wait until fully dry.



Kiesel recommends use of primers. It enhances the performance and adhesion of mortars.

**Note:** These pictographs are for general guidelines only. Follow all additional instructions located in the latest technical data sheets.

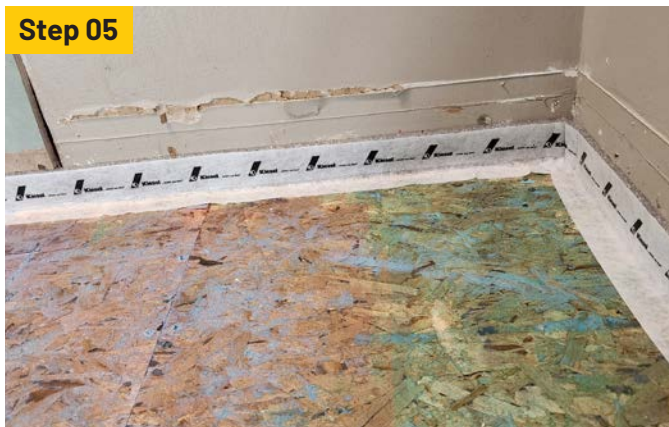

Kiesel recommends use of Kiesel wall perimeter seal gasket.

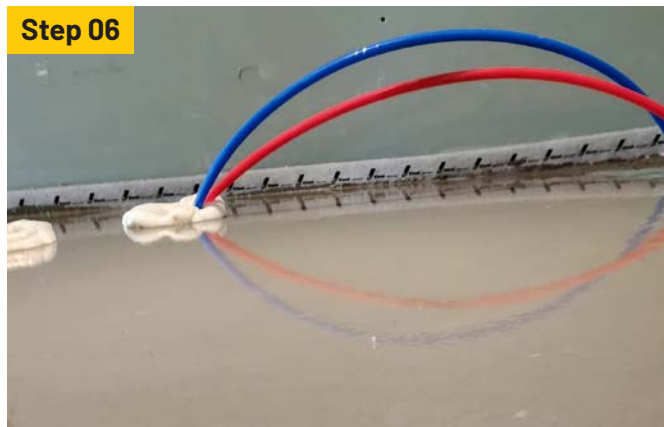

If leveling is required use Servoplan Ki 1. Must add fibers when pouring over OSB and plywood.



Wait until Servoplan Ki 1 is fully dry.

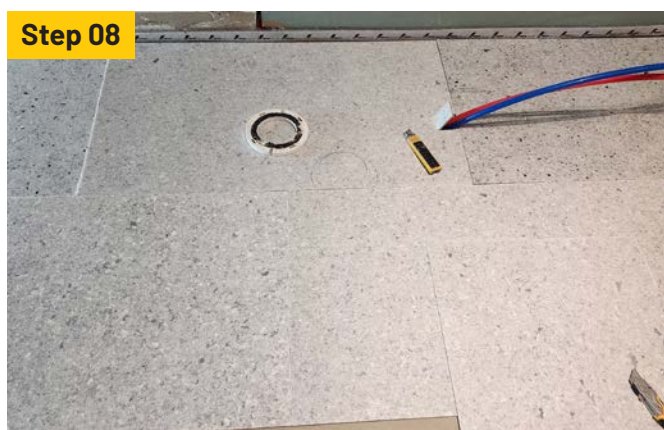

Loose lay all OkaQuiet boards in the entire room by offsetting boards by 50 % (brick joint pattern) keeping the boards tightly on all edges (butt to butt).



Score OkaQuiet with heavy duty utility knife.



Snap and cut it from the back site.



Mix Servoflex 5, Servoflex Trio SuperTec or Servoflex Pro with proper water ratio.

**Note:** These pictographs are for general guidelines only. Follow all additional instructions located in the latest technical data sheets.



Use 1/4" x 1/4" x 1/4" square notch trowel to install OkaQuiet.



Remove loosely laid OkaQuiet within hands reach (typically one row).



Spread the mortar one directional keeping the ridges high.



Embed OkaQuiet into fresh mortar cleaning billowed mortar between the boards.



Use hand or large embedding rollers or flat trowels to achieve 100 % mortar transfer.



Lift OkaQuiet occasionally to check for proper coverage.



Final example of finished installation. For sound deadening installation cover all joints with 3/4" masking tape prior to tile installation.

**Note:** These pictographs are for general guidelines only. Follow all additional instructions located in the latest technical data sheets.

## Limitations

Minimum porcelain tile is 2" x 2" (50 mm x 50 mm). The maximum porcelain tile size is 120 x 177 cm at 10mm thickness – 48" x 70" at  $\frac{3}{8}$ " thickness.

Ceramic or natural stone coverings can be installed over the OkaQuiet Board after complete hardening of the installation mortar used to bond the OkaQuiet Board. Ceramic coverings made of stoneware or porcelain tiles with a thickness of more than 8 mm are suitable.

For natural stone coverings, only correspondingly dense types (e.g., granite or gneiss) with a minimum thickness of over 15 mm or breaking strength of 1500 N.

Special considerations apply when sizing floor joists to support ceramic or stone tiles (marble, granite, limestone, slate, etc.). Tile industry associations recommend that floor joists be spaced 16 inches (40.6 cm) on center or less. The Tile Council of America recommends limiting deflection to  $L/360$  ( $L$  = span length in inches) under total load for ceramic tile. The Marble Institute of America recommends that total load deflection be limited to  $L/720$  for spans up to 14'-0" and a maximum deflection of  $\frac{7}{32}$ " for spans greater than 14'-0".

Stone tiles may be installed with thin-set methods (a 14-foot (4.26 meters) maximum span is recommended by the Marble Institute of America), and ceramic tiles may be set on a full mortar bed. Adjust the dead load as required to reflect the actual system components if they differ from those shown in these tables and apply the appropriate deflection limit for the type of tiles to be used.

## Movement Joints

OkaQuiet Uncoupling Board does not eliminate the need for movement joints, including perimeter joints, within the tiled surface. Movement joints must be installed in accordance with industry standards and norms, TCNA EJ171, and TTMAC 301 MJ

## Setting and Grouting Specifications

Setting material: C2 E-S1, C2TE-S2  
Grout: CG 2 WA, ANSI A 118.7, R2T

## Other Considerations

- Tightly butted and/or tented plywood or OSB seams must be addressed before installing OkaQuiet Uncoupling Board
- The vapor barrier on crawl space floors according to regional building codes.
- Vapor management. Use Okatmos® DSG to lower the moisture content in concrete or gypsum-based poured slabs (water radiant heating embedded in concrete cannot be used with Okatmos® DSG, use Okatmos® UG 30 instead). Follow detailed/additional information in the technical data sheets at [ca.kiesel.com](http://ca.kiesel.com) and [us.kiesel.com](http://us.kiesel.com). Not for gypsum-based substrates with higher moisture content.
- Where a waterproof floor is required, all OkaQuiet Uncoupling Board must be treated with a designated Kiesel waterproofing system.

## Specifications

Colour	Light grey
Application	Interior, walls and floors
Format	100 x 60 cm = 0,6 m <sup>2</sup> (39.37" x 23.6"=6.45 ft <sup>2</sup> )
Thickness	Approx. 4 mm ( <sup>5</sup> / <sub>32</sub> "
Weight	Approx. 2.8 kg/m <sup>2</sup> (6.2 lbs. per 10 ft <sup>2</sup> )
Crack isolation	Up to 3mm - <sup>1</sup> / <sub>8</sub> "
Thermal conductivity	Approx. 0,05 W/mk (R=0,02 ft <sup>2</sup> h °F/ btu) according to DIN 52 612 / R-Value 0.02
Thermal transition coefficient (U-Value)	23,81 W / m <sup>2</sup> K (4.176 BTU/ft <sup>2</sup> h °F) according to DIN EN
Fire classification	E
Floor heating systems	Suitable
Recycled content	90 % - post consumer
VOC	0.0 g/L
Storage	Dry and lying on a level, flat surface
Shelf life	No expiry
ASTM C627-93	Light commercial over standard, industry recognized OSB, plywood substrates, Extra Heavy over concrete substrate only.
Sound deadening properties DIN EN ISO 10140	10 dB
Packaging	10 boxes with 15 boards = 90 m <sup>2</sup> /968 ft <sup>2</sup> Board size= 100 cm x 60 cm / 39.3" x 23.63" Board m <sup>2</sup> /ft <sup>2</sup> = 0.60m <sup>2</sup> / 6.5 ft <sup>2</sup> Item no. 60170

### Sound deadening properties US/CAD:

ASTM E90-09 (2016), ASTM E413-16, ASTM E492-09 (2016) e1, ASTM E2179-21, ASTM E989-21, ASTM E2235-04 (2020), ASTM E3222-20	Testing performed by Intertek, PA on 07/18/2022 with <sup>3</sup> / <sub>8</sub> ", 10 mm thick porcelain tiles, 30 x 30 cm / 12" x 12" with full mortar transfer in thin-set assembly over 6" (152 mm)-thick concrete slab without a suspended ceiling.
STC	55
IIC	40
ΔIIC	11
HIIC	38
HΔIIC	9

**Note:**

The impact sound improvement values stated in the data sheet have been determined on the test bench by the commissioned testing institute. These values shall not be transferred to other construction projects, as the ceiling structures are different for each project. To determine the impact of sound improvement values on the object, a test installation must be carried out, and, in this context, the impact of sound value before and after the measure must be determined on-site.

Kiesel cautions against a one-to-one application of acoustic ratings provided by manufacturers. Currently, it is impossible to predict the performance of acoustic underlay without considering the environmental conditions (i.e., building structure) in which it will be used. Verifying the requirements under which the manufacturer performed the published acoustic tests is essential to determine whether the published acoustic ratings will apply with a similar outcome in the field. Verification of whether the testing was conducted in a laboratory (IIC = Impact Insulation Class) or the field (FIIC = Field Impact Insulation Class) will significantly impact acoustical rating results. Acoustic tests performed in a laboratory (under perfect conditions) systematically provide more efficient results resulting in a higher rating than field tests. Field tests provide less than optimal testing conditions and will influence acoustical rating results often by up to 5 points. Verification of usage of a floor/ceiling assembly that is equal to the intended installation during the acoustic testing will also significantly impact the applicability of the acoustic testing results. As an example, the use of a suspended ceiling can influence acoustical rating results by up to 14 points. Other considerations to verify that will dramatically influence published acoustic results for a given membrane are the thickness of the concrete slab, the amount and thickness of plywood layers, the use of the resilient channel, and the existence of a suspended ceiling acoustical mat, et al.

 **$\Delta$ IIC (Delta IIC) vs IIC**

The Delta IIC rating is representative of the product performance in isolating impact footfall noise, which is in addition to the assembly.

The Delta IIC test rating is a result of

- 1) Testing of a complete assembly consisting on average of six to eight inches of concrete, with nothing above or below the concrete
- 2) Testing of the complete assembly in Step 1 with the addition of underlayment installed directly on the concrete

The Delta IIC rating is the performance difference (Delta) in isolating impact footfall noise between the first and second tests. The higher the number, the better the performance. The Delta IIC rating is the best rating to consider when comparing the performance of different types of underlayment as it is the most true to usage performance rating.

Misleading or easily misinterpreted results can most often be found with IIC ratings of 60 IIC or above using materials less than 1/2" thick. IIC results are typically obtained using materials or isolation methods that average assemblies do not use or are not true to usage. The high IIC ratings are typically achieved with decoupled ceilings and considerable additional mass which will be erroneously attributed to the thin underlayment. If the IIC rating is unreasonably high, ask to see a Delta IIC rating. If not provided a Delta IIC rating, then the best step is to ignore the advertised rating or ask for test methodology (e.g. assembly materials and methods of measurement) to draw a more accurate conclusion.

# OkaQuiet – General information

Synthetic resin-bonded, stable and highly compressed, approx. 4 mm /  $\frac{5}{32}$  thin with blended recycled synthetic fibre board for uncoupling and sound deadening substrates installed with suitable resilient, textile covering, engineered and hardwood flooring. As an insulating intermediate layer in renovation work and on poorly insulated substrates in old and new buildings. Increases living and walking comfort at low installation heights. OkaQuiet is water resistant and will not deteriorate

## What is uncoupling?

Uncoupling, separates the surface covering from the substrate so that the surface covering and substrate have no direct connection. This prevents stresses, displacements and vibrations of the substrate from being transmitted directly to the surface covering – they are reduced or absorbed completely.

## Possible applications

There are countless possible applications, from tiles over cementitious screeds or levellers to wooden substrates such as resilient, hardwood and engineered flooring coverings.

## How is the uncoupling effect of Kiesel OkaQuiet Uncoupling Board products created?

All Kiesel uncoupling products (except Kiesel crack isolation fleece) are built up on a multi-layer basis, i.e. most of the stress and movement reduction takes place in the core of the decoupling product. The built-in adhesive film in the OkaQuiet product prevents penetration of the applied mortars.

### Example: OkaQuiet Uncoupling Board (section / structure)

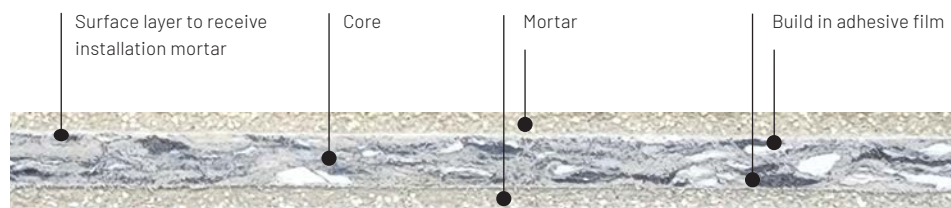

5 different layers with a total thickness of 4.0 mm /  $\frac{5}{32}$ "

Each individual layer absorbs part of the stresses and movements that occur. This considerably relieves the pressure on the surface layer's setting mortar and the setting mortar of the decoupling element.

## (\*\*\*) HEATING PROTOCOL

### WITH WATER RADIANT FLOOR HEATING:

#### General guidelines for underfloor heating:

- The underfloor heating system should be installed according to the supplier's instructions. An incorrectly installed underfloor heating system can cause the screed to become unfastened or the floor covering to lose shape.
- Damage to the floor or the underfloor heating pipes resulting from incorrect installation and causing the finish layers to show incomplete covering is beyond the liability of the installer of the floor and his suppliers.
- After applying the screed, wait for a minimum of 28 days, then gradually heat up the underfloor heating system by a maximum of 5° C / 41° F per day.
- Next, ensure the underfloor heating system is switched on uninterruptedly for 14 days so that the floor can be set and any residual moisture can quickly evaporate.
- Switch off the heating system at least 24 hours before levelling/applying floor covering.
- Switch on the heating system at least 24 hours after levelling/applying a floor covering and gradually raise the water temperature by a maximum of 5° C / 41° F per day. Concrete Core Activation

The above guidelines equally apply if a concrete core activation (CCA) system has been installed in the floor construction and outdoor temperature-dependent temperature control is used. The temperature will vary from 17° to 28° C / 62° F to 82° F in this case. Another system often used is based on a constant temperature of 22° C / 72° F. If the floors to be covered have been installed with this system, no further precautions will be needed.

CCA CCC is an abbreviation of concrete core activation, an innovative climate control system used to heat and cool corporate buildings. Flexible pipes are placed at the heart of the concrete

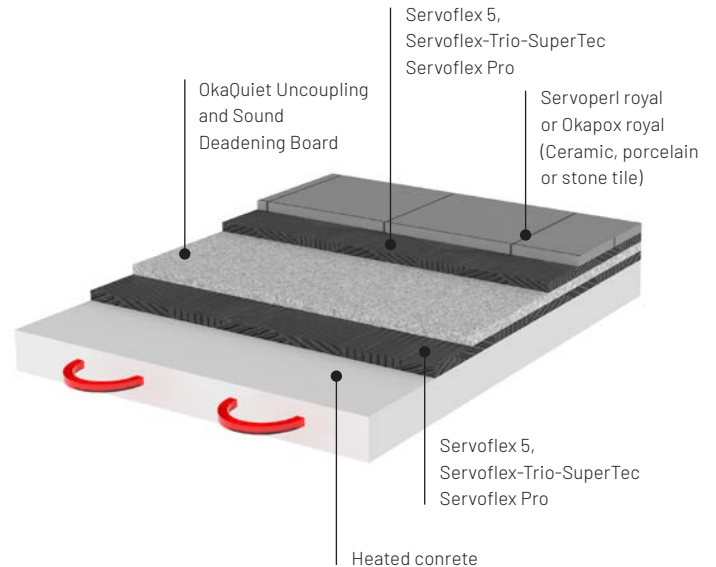

flooring, and water is pumped through the pipes at a constant temperature. The energy is primarily derived from the ground. During the summer, relatively cool groundwater is pumped through the pipes and/or to the air treatment installation, heated up by the warmer floor and returned to the ground at another place. During winter, the water is pumped back up again, heated by a heat pump and sent through the pipes at a higher temperature to heat the building.

The EN12667:2001 norm is used for our TFD floors  
For 2 mm, the value is 0,021 m<sup>2</sup> K/W.  
For 3 mm, the value is 0,041 m<sup>2</sup> K/W.  
For MAG, the value is 0,04 m<sup>2</sup> K/W.  
For Click, the value is 0,033 m<sup>2</sup> K/W.

#### Heating and cooling protocol

This heating and cooling protocol should, preferably, be followed through several times before a floor covering or finish is applied (synthetic floor, tiles, flagstones, parquet, laminate, Marmoleum etc.). Under-floor heating is seen as a hot water

pipe (system) installed in a floor in this heating and cooling protocol. The floor above the pipe must be at least 25 mm / <sup>15</sup>/<sub>16</sub>" thick. Screeds in which an underfloor heating system has been installed can tear as a result of thermal changes in length. In order to minimize this risk, it is necessary to heat up the system at a slow, regular pace. It is advisable to use the heating and cooling protocol below for this purpose. A heating and cooling protocol for underfloor heating is based on the temperature of the water in the heating system and not the thermostat temperature in the room. It is sensible to continue the process until the water has reached a temperature of 40° C / 104° F at the highest. Generally speaking, the water temperature should not exceed a maximum of 40° C / 104° F. Many installers suggest 55° C / 131° F as a maximum temperature; however, this considerably raises the risk of tearing and unfastening. If it is not

absolutely necessary to stick to 55° C / 131° F , adapting the heating protocol to a 40° C / 104° F limit is recommended. Certainly, do not go beyond 55° C / 131° F, as this will vastly increase the risk of damage! What is also important is that the screed has roughly reached its final strength. This means that cement-based screeds, preferably, should not be heated up until at least 28 days after they have been installed. Calcium sulphate-based screeds, depending on the quality of the mortar, can be heated up slightly sooner, as calcium sulphate has a higher internal flexural strength. How much sooner is difficult to say, as this depends entirely on the circumstances in which the floor has been left to dry. A general rule of thumb is that a calcium sulphate floor should not contain a moisture weight percentage of more than 3 %. This should be measured with a carbide-method hygrometer or professional industry-recognized measuring devices.

#### **Note:**

Most cracks do not occur during heating but during cooling. This means the cooling phase is, in fact, even more, important than the heating phase, and it is vital to maintain the proper pace during cooling.

- Start with a water temperature of 5° C / 41° F above ambient temperature. The water temperature should be taken from the heating system.
- Raise the water temperature every 24 hours (or longer) by 5° C / 41° F until the rough maximum water temperature of 40° C has been reached (see earlier comments on this).
- Maintain a steady maximum water temperature of 40° C / 104° F for at least 24 hours.
- Next, reduce the water temperature every 24 hours by 5° C / 41° F until the original temperature has been reached. More and more underfloor heating systems also offer cooling. For these systems, it is vital (especially during the summer, when temperatures are high) that the cooling cycle is continued until the minimum temperature of the heating and cooling unit is down to 15° C / 59° F.
- If time allows, repeat this cycle several times.
- It is advisable to give the end user/consumer a copy of the heating and cooling protocol so as to ensure normal usage after delivery – as the protocol must also be followed whenever the underfloor heating system has been deactivated for a long time

The aforementioned information, especially the proposals for processing and utilizing our product, is based on our knowledge and experience. We recommend that you carry out your own tests in every case to ensure the suitability of our products for the intended process and processing purposes because of the different materials and the working conditions which lie beyond our area of influence. No liability can be derived from this advice or from verbal advice unless we are responsible for (criminal) intent or gross negligence in this respect.

**WWW.US.KIESEL.COM**

**WWW.CA.KIESEL.COM**



[www.us.kiesel.com](http://www.us.kiesel.com)



[www.ca.kiesel.com](http://www.ca.kiesel.com)

**Kiesel Bauchemie  
GmbH u. Co. KG**  
Wolf-Hirth-Strasse 2  
73730 Esslingen  
Tel. +49 711 93134-0  
Fax +49 711 93134-140  
[kiesel@kiesel.com](mailto:kiesel@kiesel.com)

Technical Department  
of North America  
Toll-Free: 1.888.KIESEL1(5437351)  
[info.canada@kiesel.com](mailto:info.canada@kiesel.com)  
[info.usa@kiesel.com](mailto:info.usa@kiesel.com)  
[www.us.kiesel.com](http://www.us.kiesel.com)  
[www.ca.kiesel.com](http://www.ca.kiesel.com)

